



3 LA CONFIGURAZIONE A GETTO FRAZIONATO A GOCCE MICRONIZZATE NE ESALTA L'EFFETTO DI SPEGNIMENTO

2 PASSAGGIO DALLA POSIZIONE DI CHIUSURA AL MASSIMO ANGOLO DI EROGAZIONE IN SOLI 180°

4 PRESA ERGONOMICA

1 CORPO RINFORZATO IN FIBRA DI VETRO

5 NASELLI



CARATTERISTICHE TECNICHE

Articolo	891
Norme	UNI 114 23
Massima Pressione di esercizio	16 bar
Diametro Ugello	DN 17 mm
Peso	480 gr

DENOMINAZIONE	MATERIALE
Corpo	Propilene rinforzato fibra di vetro
Testa	Propilene
Ugello	Ottone

PRINCIPALI CARATTERISTICHE IDRAULICHE come da rapporto di prova CSI ugello 0011/DC/EST/20_3

Gittata a getto pieno a 2 bar	26 m
Gittata a getto frazionato (45°) a 2 bar	22 m
K. solo lancia	110
K su sistemi di idraulica a muro	Getto pieno 174 - getto frazionato 200

CARATTERISTICHE DIMENSIONALI

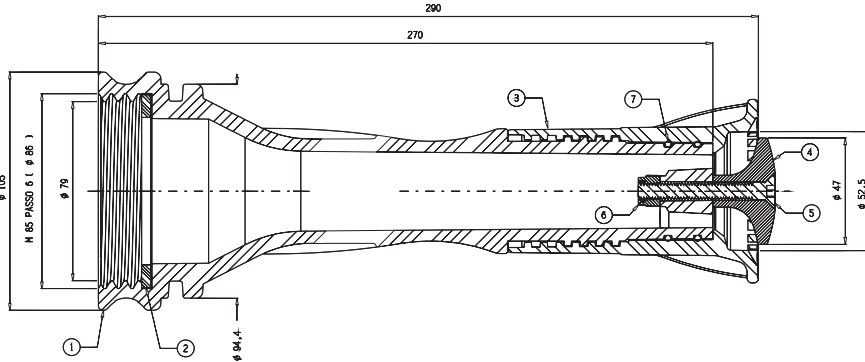
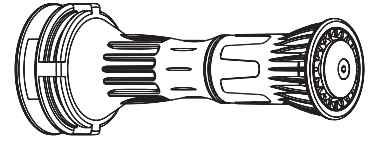

POS.	DESCRIZIONE
1	CORPO LANCIA 70
2	GUARNIZIONE UNI 70
3	TESTA 70
4	UGELLO in ottone
5	VIE M8 x 55 ACC. INOX
6	DADO M8 autobloccante INOX
7	O.R.

GRAFICO PORTATA

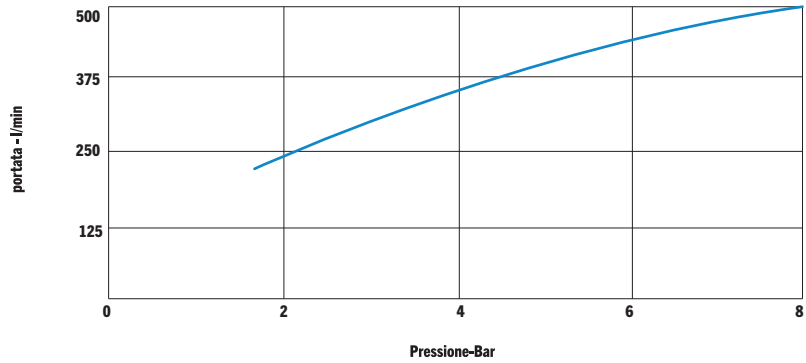

TIPOLOGIE CONNESSIONI LANCE

UNI 70	GAS 2" 1/2 F	BS 336 2" 1/2	BS 336 2" 1/2	STORZ B
Su corpo lancia	Su corpo lancia	Alluminio	Ottone	Alluminio



Art. 891 (STD)	Art. 891G	Art. 891BSAL	Art. 891BSOT	Art. 891STAL
----------------	-----------	--------------	--------------	--------------

STORZ B	DSP 65	NH 2" 1/2	GOST 70	BARCELONA 70
Ottone	Alluminio	Ottone	Alluminio	Alluminio



Art. 891STOT	Art. 891DSPAL	Art. 891NHOT	Art. 891GSTAL	Art. 891BCNAL
--------------	---------------	--------------	---------------	---------------

n.b: le immagini inerenti ai filetti di attacco alle lance non sono da considerarsi.

CERTIFICATO

THIS CERTIFICATE REMAINS THE PROPERTY OF CSI SPA



Registrazione numero / Registration number **0705b/20**

ATTESTATO DI CONFORMITA' DECLARATION OF CONFORMITY

Visto il Rapporto di Prova / Referring to the Test Report
n. 0011\DC\EST\20_3 del / dated 25/03/2020

si dichiara che il prodotto/ we declare that the product

**Lancia a rotazione DN 70 per sistemi fissi
antincendio con ugello Ø 17 mm**
*DN 70 rotational nozzle for fixed firefighting systems with Ø
17 mm nozzle*
Mod. PANAMA DN 70 (2"1/2)

prodotto dalla Società/ manufactured by the Company

SAPIN SPA
Viale dell'Industria, 12 - 20036 DAIRAGO (MI) - ITALY

è conforme alla norma UNI 11423:2011
complies to the standard UNI 11423:2011

Prima emissione / First issue: 07/05/2020
Ultima emissione / Last issue: //

Ing. P. Fumagalli
B.A. Prodotto/Product



GG002 REV.00

CSI S.p.A. A SOCIO UNICO
SOGGETTA AD ATTIVITÀ DI DIREZIONE E
COORDINAMENTO DI IMQ GROUP S.r.l.

REA MI 1466310
R.I./C.F./P.I. 11360160151
Cap. Soc. € 1.040.000

Sede legale
Italia | 20030 Senago (MI) | Cascina Traversagna 21
direzione-csi@legalmail.it | info@csi-spa.com | www.csi-spa.com

pag. 1/1